



# THE GRIFFEN TRADITIONAL



**CHARTER** Homes & Neighborhoods



# THE GRIFFEN CLASSIC



CHARTER Homes & Neighborhoods



SHOWN WITH OPTIONAL DORMERS

# THE GRIFFEN ESTATE



**CHARTER** Homes & Neighborhoods



# THE GRIFFEN FORMAL



**CHARTER** Homes & Neighborhoods

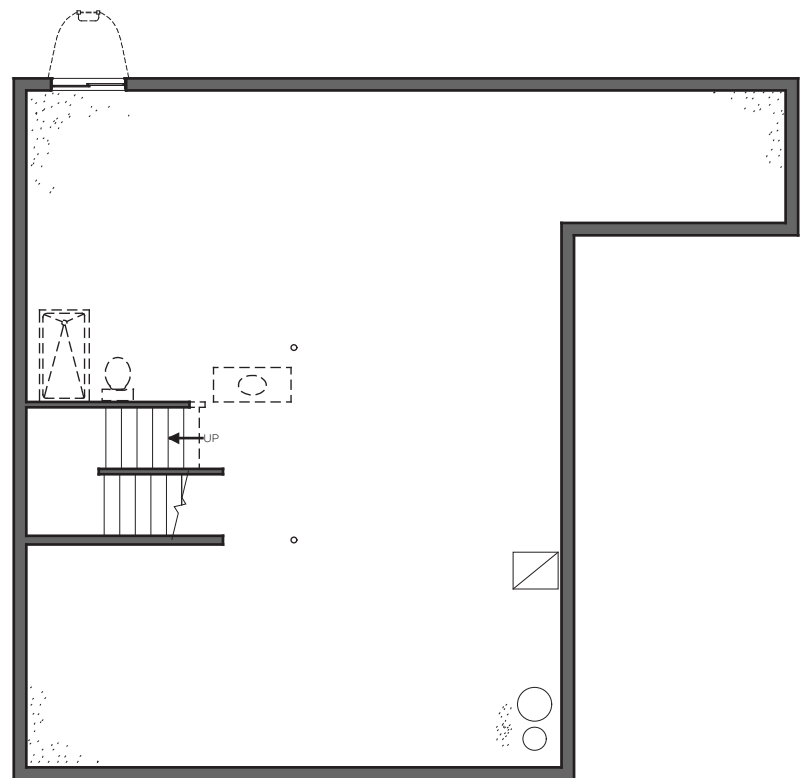
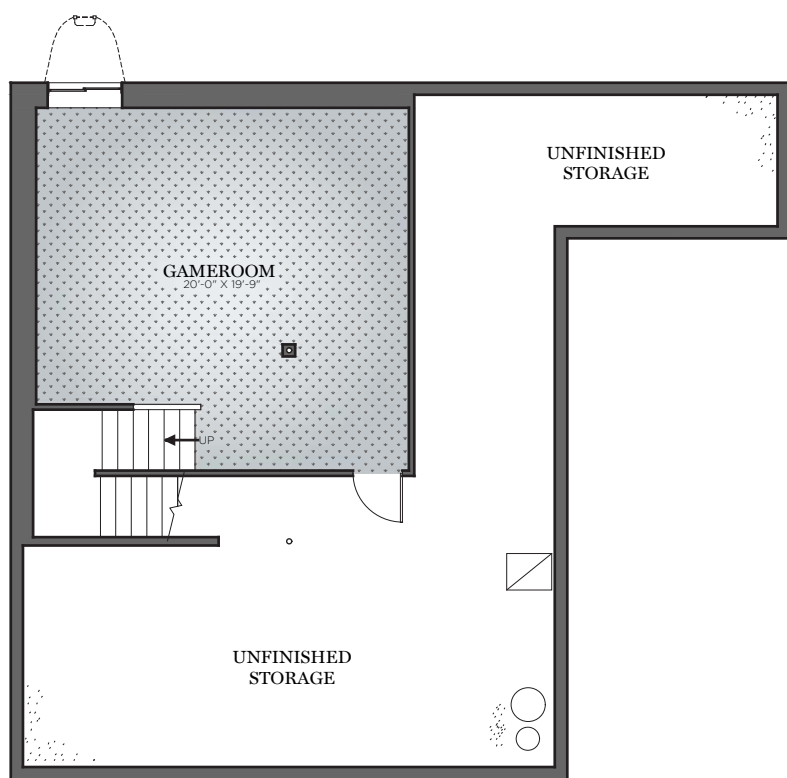
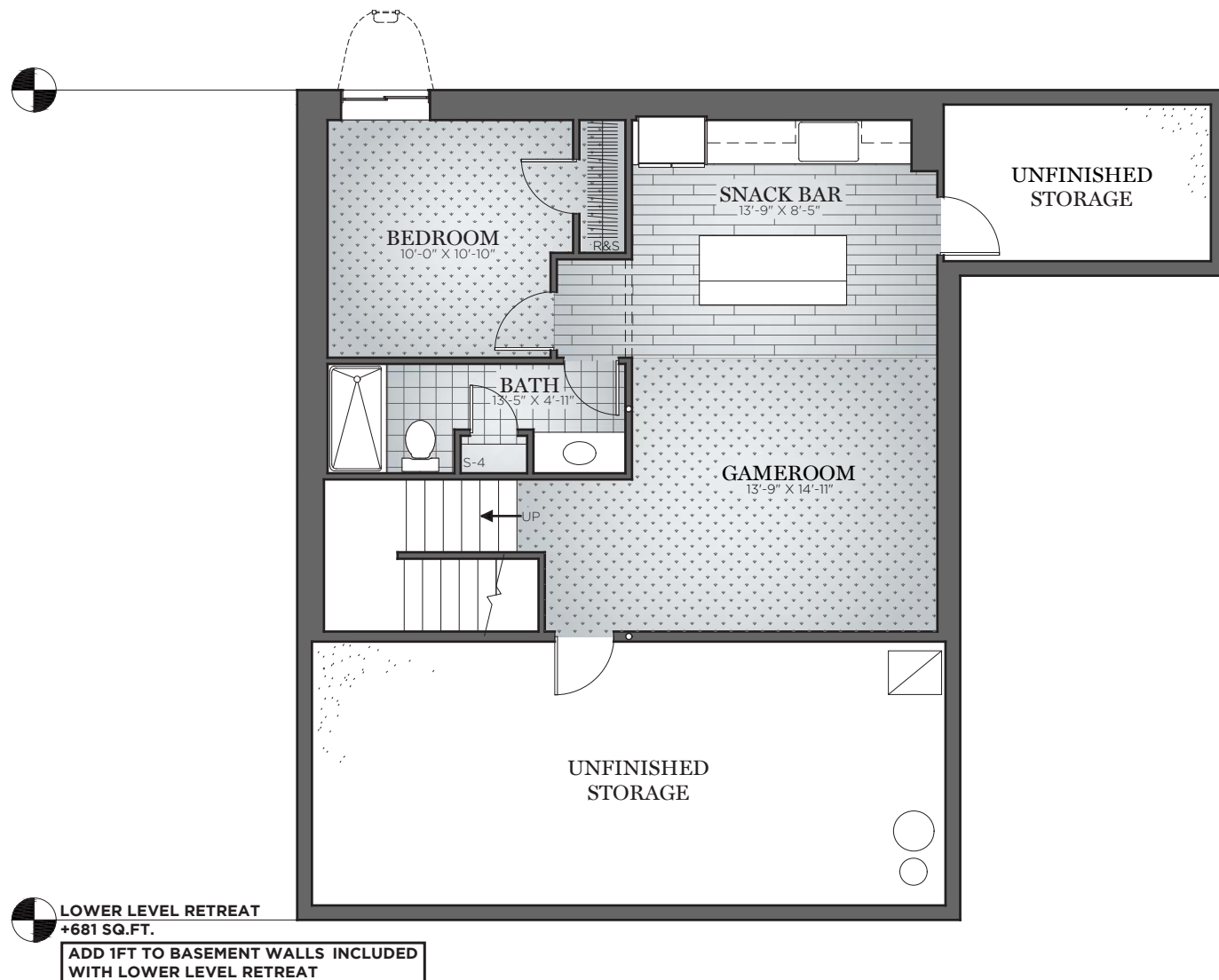
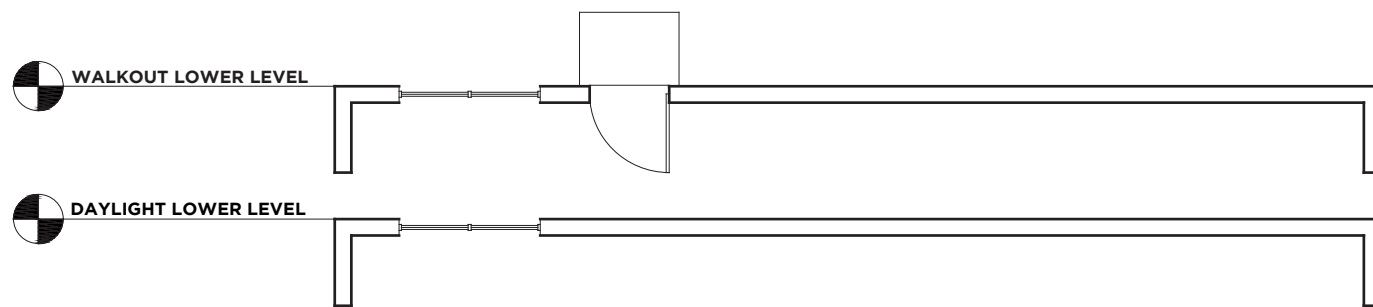

LOWER LEVEL MODIFY FLOOR PLAN  
OA DIMENSION 50 X 44

THE GRIFFEN



CHARTER Homes & Neighborhoods

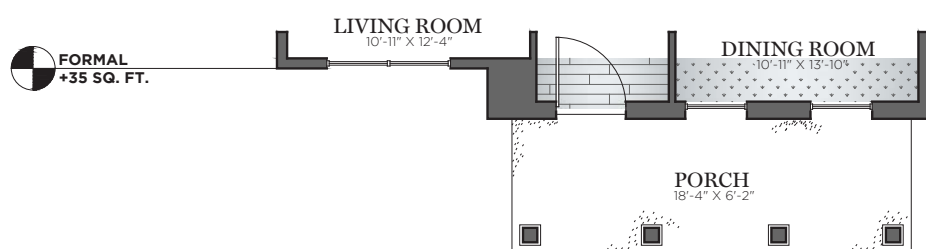
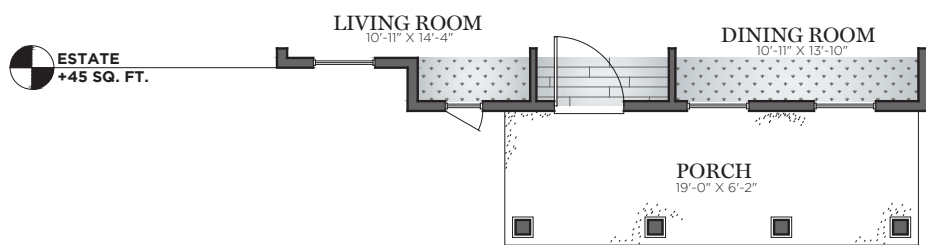
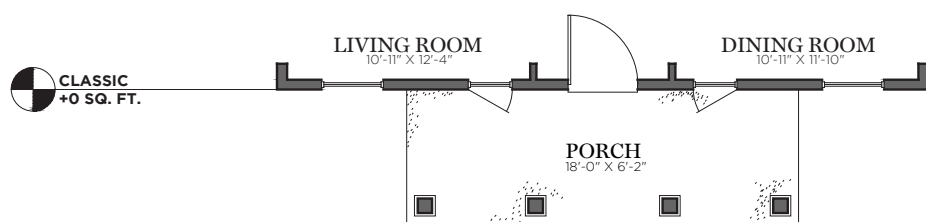
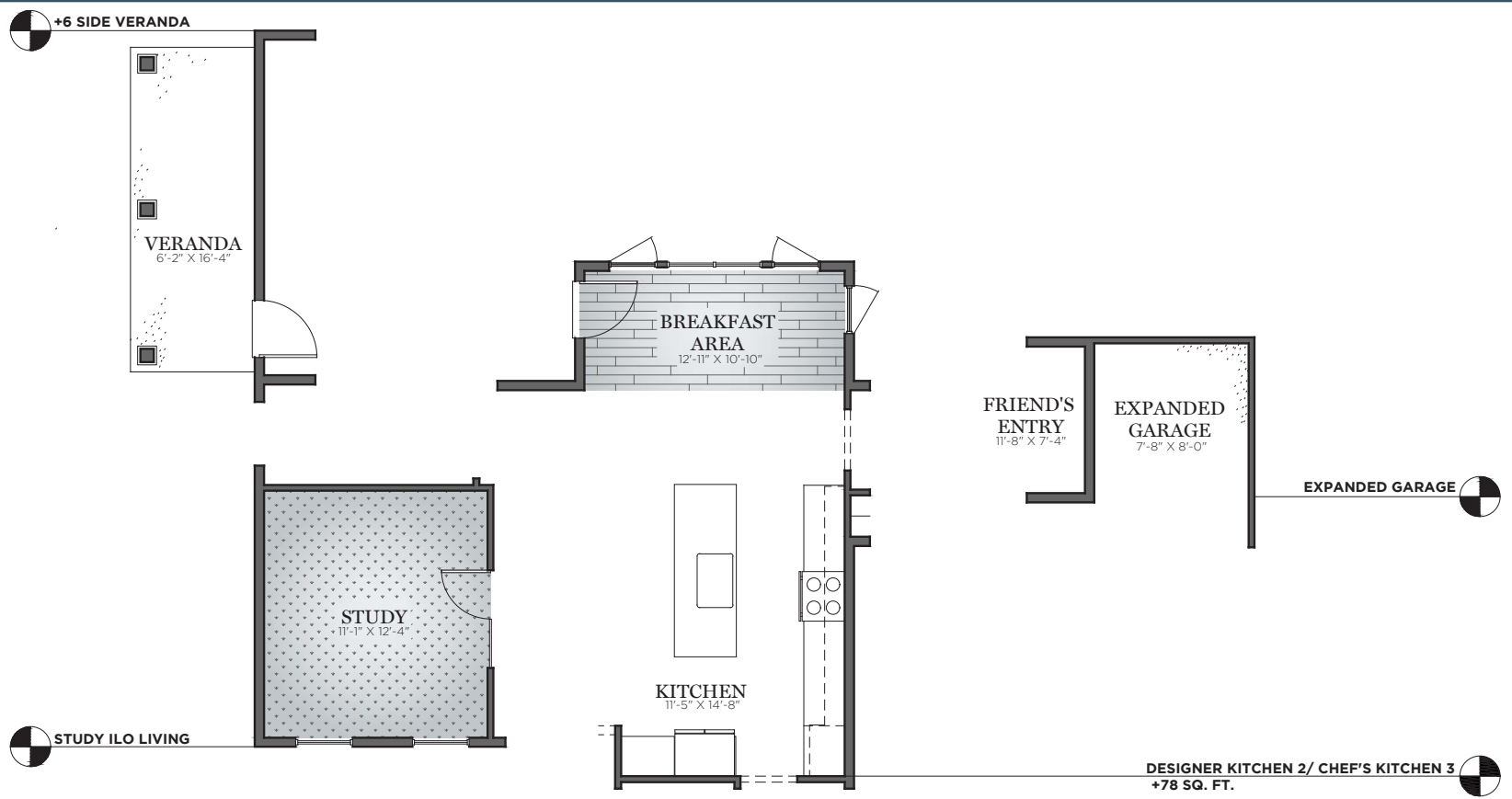

FIRST FLOOR MODIFY FLOOR PLAN  
OA DIMENSION 50 X 44

THE GRIFFEN



CHARTER Homes & Neighborhoods

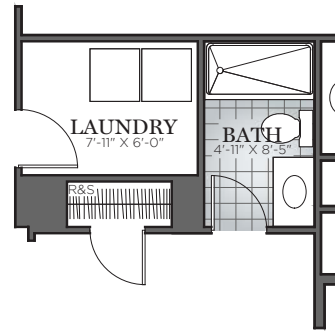
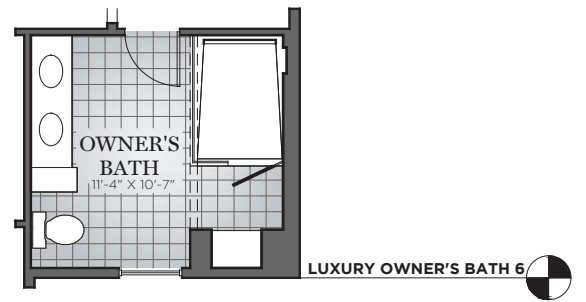
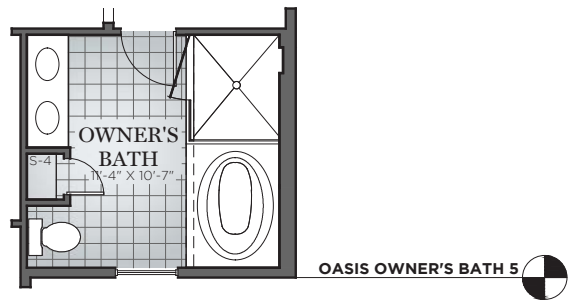

ADD FULL BATH

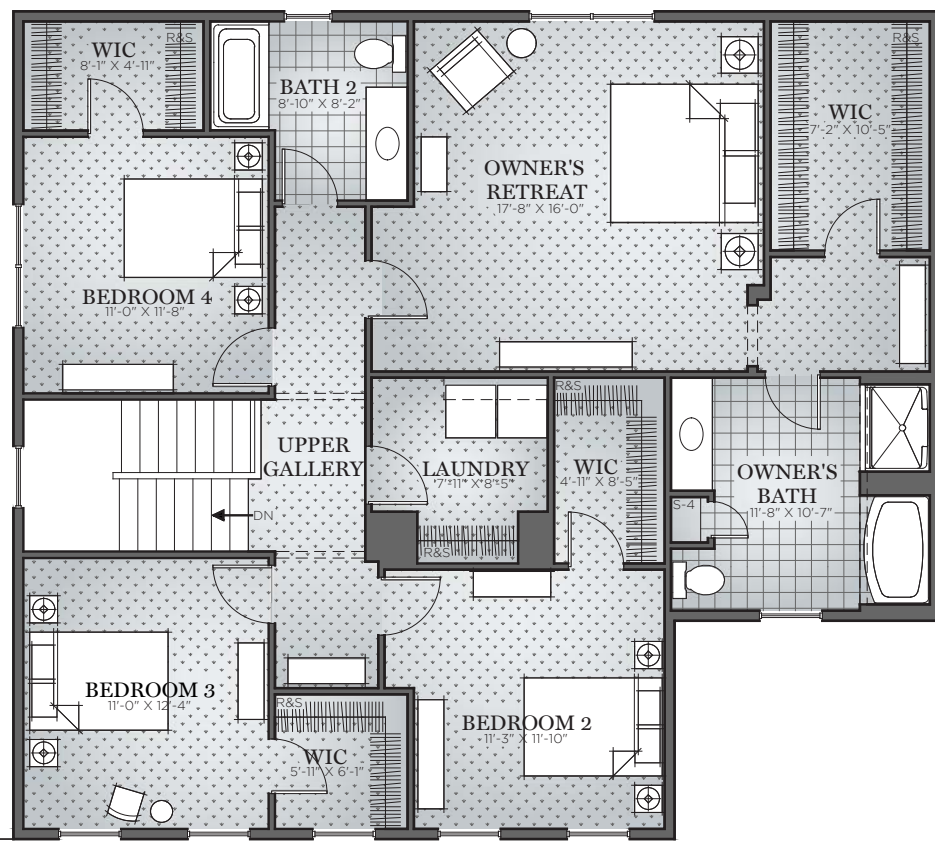

9' CEILING HEIGHT

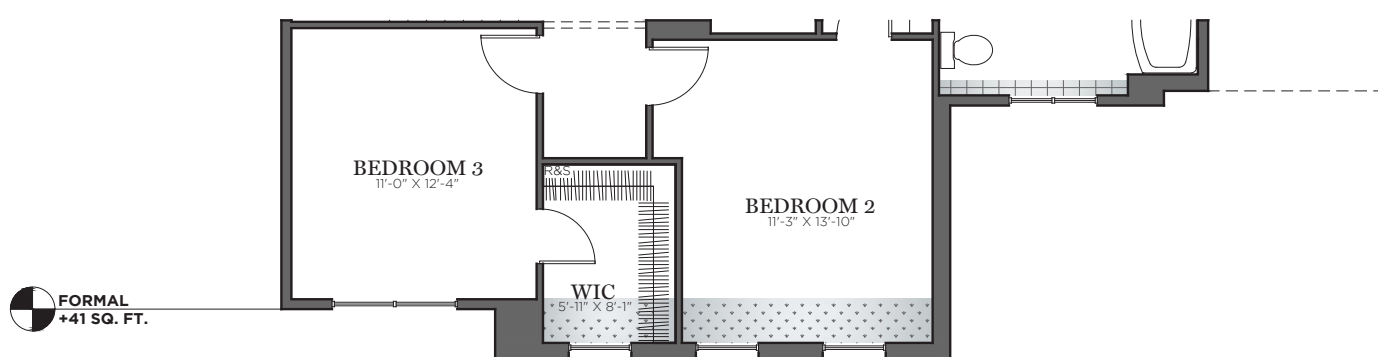
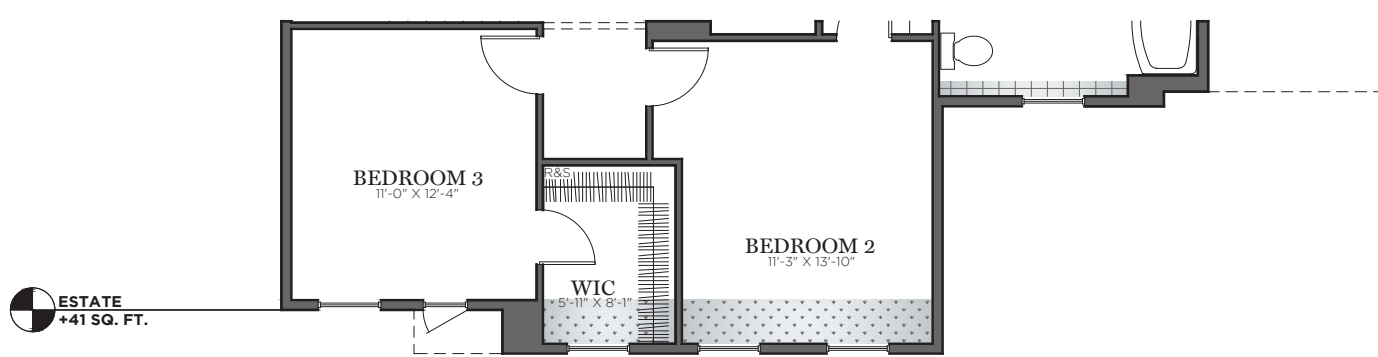

SECOND FLOOR MODIFY FLOOR PLAN  
OA DIMENSION 50 X 44

THE GRIFFEN



CHARTER Homes & Neighborhoods

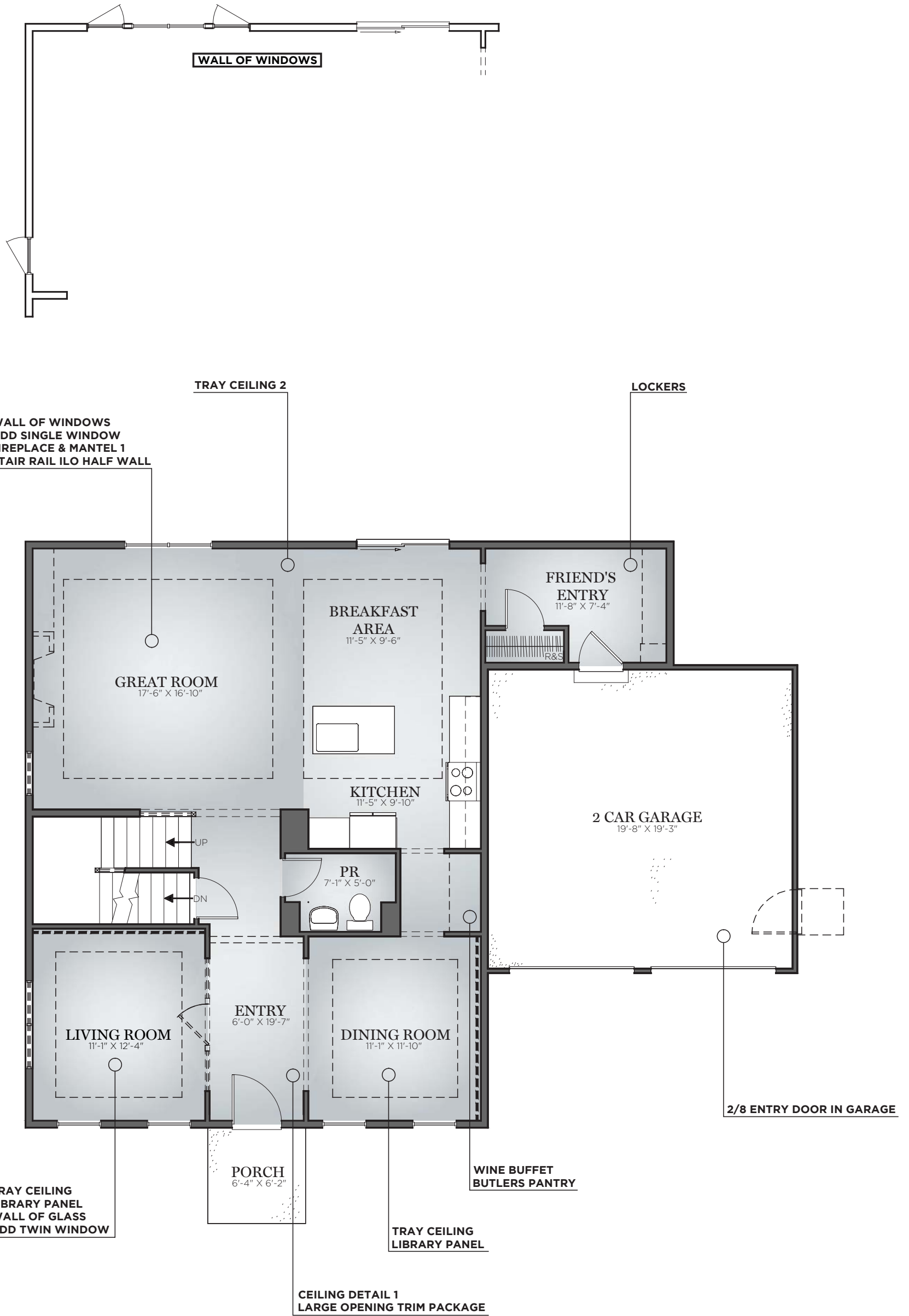

## FIRST FLOOR ADD DETAILS

OA DIMENSION 50 X 44

# THE GRIFFEN



CHARTER Homes & Neighborhoods



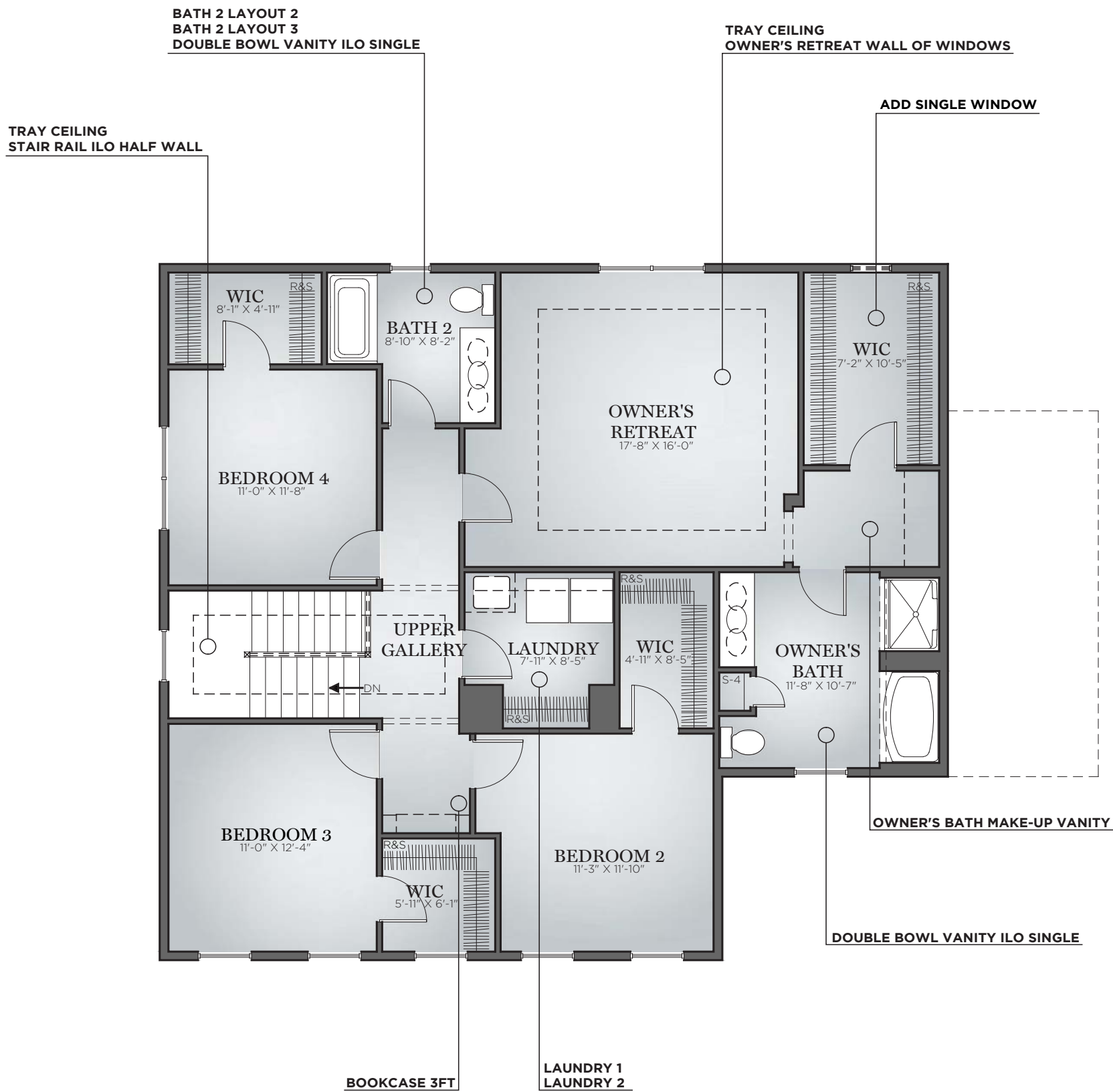
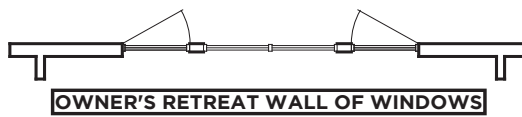

**SECOND FLOOR ADD DETAILS**  
 OA DIMENSION 50 X 44

THE GRIFFEN



CHARTER Homes & Neighborhoods



 **CHARTER** Homes & Neighborhoods

CLASSIC  
KITCHEN B

THE GRIFFEN

Island Top Dimensions are 3'-1" x 5'-3"  
 Wall Cabinet height 42"  
 Appliance finish and features will vary per selection  
 Refrigerator is not included in appliance package  
 Finishes including cabinets, flooring, lighting, tile, plumbing,  
 and hardware to be selected at Charter Colors  
 Pendant lighting not included

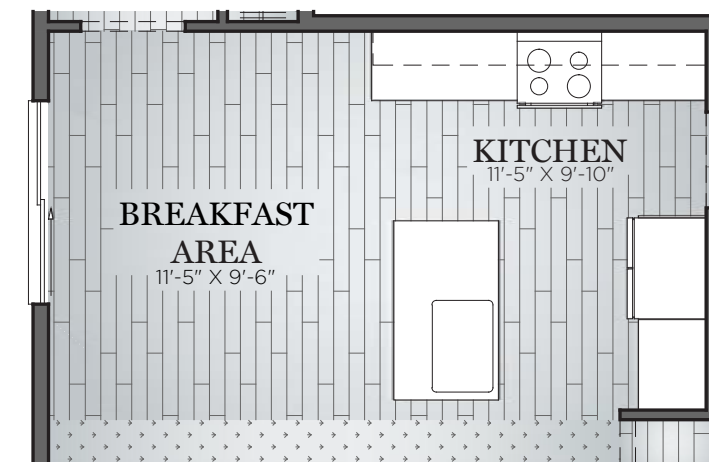

PLAN



 **CHARTER** Homes & Neighborhoods

DESIGNER  
KITCHEN 2

THE GRIFFEN

Island Top Dimensions are 3'-1" x 8'-8"  
 Wall Cabinet height 42"  
 Appliance finish and features will vary per selection  
 Refrigerator is not included in appliance package  
 Finishes including cabinets, flooring, lighting, tile, plumbing,  
 and hardware to be selected at Charter Colors  
 Pendant lighting not included

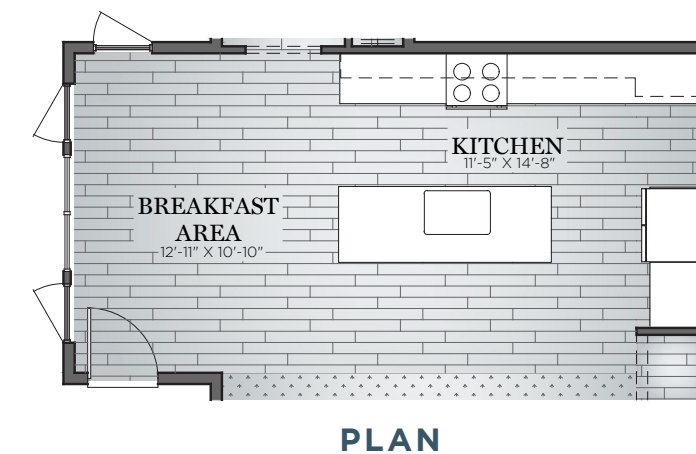



 **CHARTER** Homes & Neighborhoods

## CHEF'S KITCHEN 3

# THE GRIFFEN

Island Top Dimensions are 3'-8" x 9'-5"  
 Wall Cabinet height 42"  
 Appliance finish and features will vary per selection  
 Refrigerator is not included in appliance package  
 Finishes including cabinets, flooring, lighting, tile, plumbing,  
 and hardware to be selected at Charter Colors  
 Pendant lighting not included

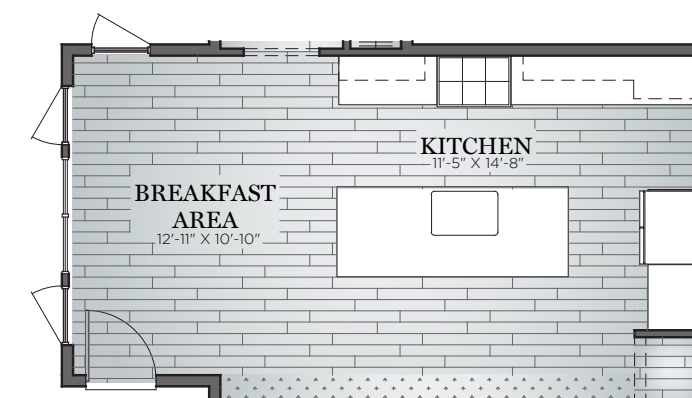

**PLAN**



**SPA OWNER'S BATH 4**



**RETREAT BATH 3**



**TRADITIONAL BATH 2**

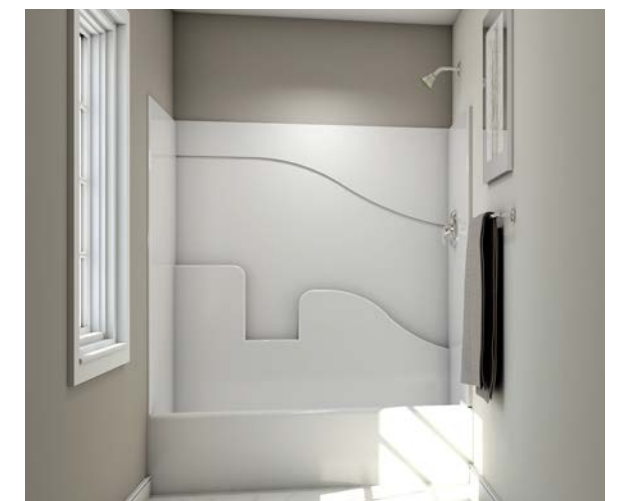

**CLASSIC BATH B**

 **CHARTER** Homes & Neighborhoods

# THE GRIFFEN

Tile locations vary per floorplan  
 Bathroom layout varies per floorplan  
 Finishes including plumbing, lighting, tile, vanities, sinks,  
 and doors to be selected at Charter Colors



OASIS OWNER'S BATH 5



CHARTER Homes & Neighborhoods

THE GRIFFEN

Tile locations vary per floorplan  
Bathroom layout varies per floorplan  
Finishes including plumbing, lighting, tile, vanities, sinks,  
and doors to be selected at Charter Colors



**LUXURY OWNER'S BATH 6**



**TOWEL CUBBIE CABINET**  
 -FULL REAR WALL OF TILE TO MATCH  
 SHOWER SELECTION  
 -WOOD TOP WITH BACKSPASH  
 -RECESSED LIGHT INCLUDED



# THE GRIFFEN

Tile locations vary per floorplan  
 Bathroom layout varies per floorplan  
 Finishes including plumbing, lighting, tile, vanities, sinks,  
 and doors to be selected at Charter Colors